



Packaging Industry

SPEEDFORMER KMD 90 Premium



The KMD 90 Premium is designed for special customer's needs and equally an universal genius.

The machine is used for the manufacture of packaging products made of (R)PET, PP, PS, CPET, OPS, PLA, PE and others.

Raise yourself into a new dimension!

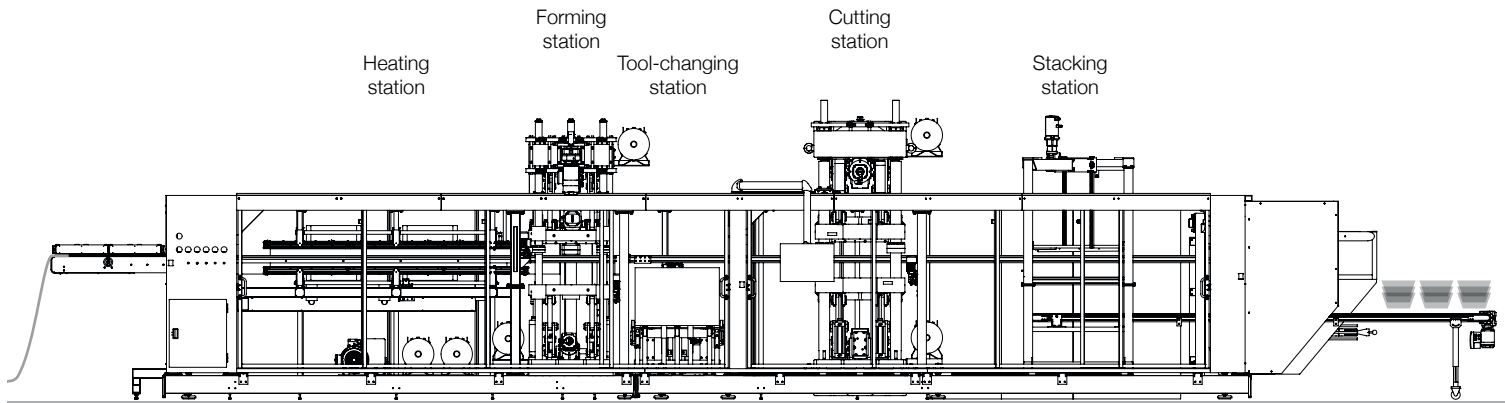

Automatic Pressure
Forming Machine
KMD 90 Premium



Tool-changing station for quick tool-change in one block



Pick & Place to opposite operator side, convenient height of reception



Slug-removal station (e.g. Euro-holes)

- Upper and lower heating banks with efficient black ceramic heating elements and closed loop temperature control available
- Forming station with independent servo-plug drive on upper and/or lower table
- No compromise on Kiefel „KISS CUT“ by use of tension bars in cutting station
- Stacking station design as up-stacker or down-stacker, with tip-stacker or Pick & Place available
- Tooling from series Sencorp 2500 can be adapted easily



Reliable stacking, high availability of the machine

Technical Data	KMD 90 Premium
Maximum forming area	865 x 915 mm (34" x 36")
Minimum forming area	355 x 350 mm (14" x 13.8")
Maximum tool dimensions	890 x 940 mm (35" x 37")
Maximum tool weight per table	600 kg (1300 lbs)
Maximum height of formed part above film level	160 mm (6.30")
Maximum height of formed part below film level	160 mm (6.30")
Maximum film width	925 mm (36.40")
Maximum production speed	30 cycles/min.